

skypod®

Issue 4

INSTALLATION GUIDE



CONTENTS

1. Preparing to install	2
2. Installation	4
3. Installing jack rafters	13
4. Installation examples	14



BE SAFE WHEN WORKING AT HEIGHT

Ensure you conform to the latest Work at Height Regulations. For more details, visit:

www.hse.gov.uk/work-at-height

If in doubt at any stage

Please contact our Conservatory Roof Team for additional support or advice.



0333 777 3057

INSTALLATION GUIDE

SURVEYING WARNING

Good surveying is essential to ensure a trouble free successful installation and to avoid costly remakes caused by incorrect measuring.

When surveying it is the surveyor's responsibility to determine that the structural openings and surrounding areas are in a state of good repair and provide the correct dimensions for manufacture.



1. PREPARING TO INSTALL

1.1

Before unpacking the Skypod pitched lantern roof, you should review the supplied layout drawing (shown right). This will be located in the ancillary box.

The dimensions shown on this plan are for the external face of the supporting upstand. Ensure these dimensions are consistent with the host building.

The Skypod ring beam allows a 10mm tolerance per face if the overall width and length of the upstand perimeter are oversized.

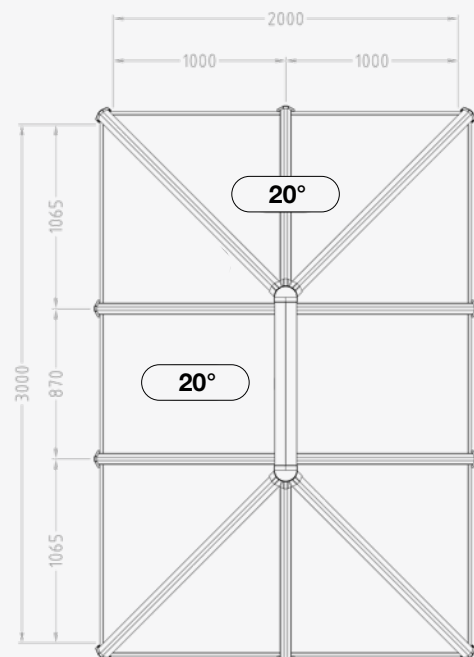

1.2

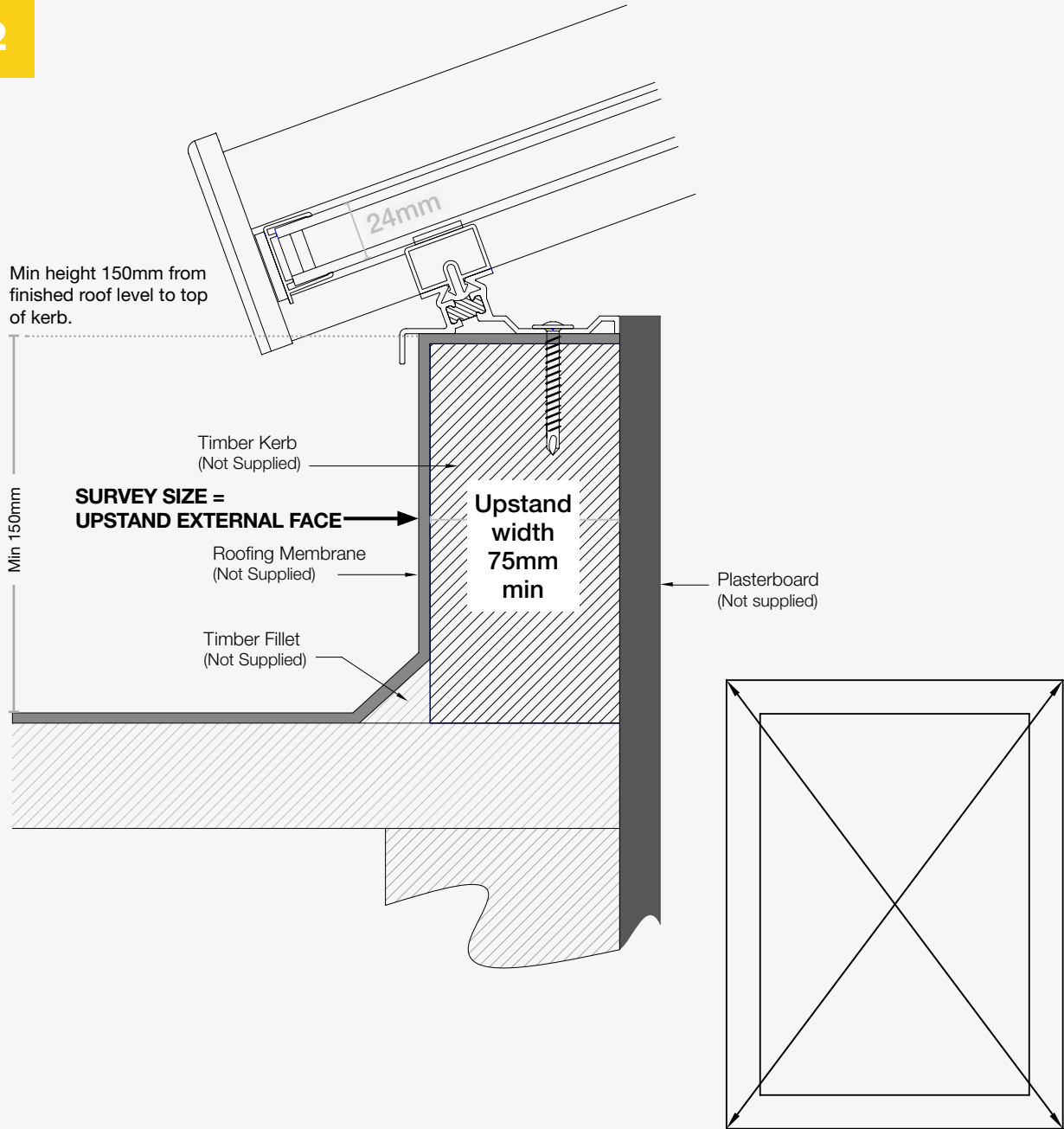
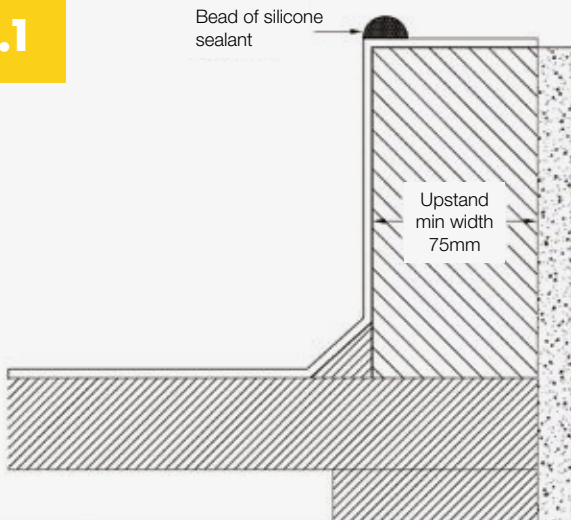

Fig. 2

The upstand corners should also be square. Check the difference between the diagonals to see if the ring beam overhang will need adjusting around the perimeter, as well as checking the diagonals to ensure the kerb is square (see Fig. 2). Kerb height should be a minimum of 150mm above the finished roof level and in the case of protected roof systems this is where the top of paving, gravel, planted vegetation etc. is the finished roof level.

2. INSTALLATION

2.1



Ensure the kerb is clean and free from debris, then run a silicone bead around the external edge as shown above.

2.2

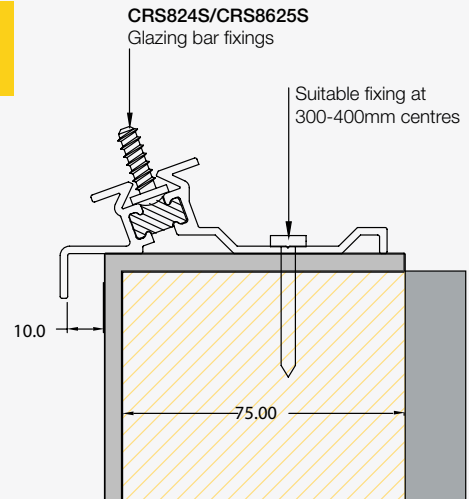

Ensure correct amount of glazing bar fixing studs are slid into the ring beam before any fixing commences. Position the ring beam so an equal overhang is achieved around perimeter and fix using suitable 5-6mm fixings at 300-400mm centres (starting and ending 100mm away from internal corner of the ring beam).

2.3



Run a bead of silicone sealant along the mitred edge of the ring beam to seal the corner joint, when the next ring beam is offered up.

2.4



Fix the adjacent ring beam ensuring the joint is tight. Remove any excess sealant and secure corner using a steel corner cleat with 4-off 4.8x25 LG screws (supplied).

FOR SKYPOD (PVC-U RAFTER TOP CAPS) ONLY

2.5

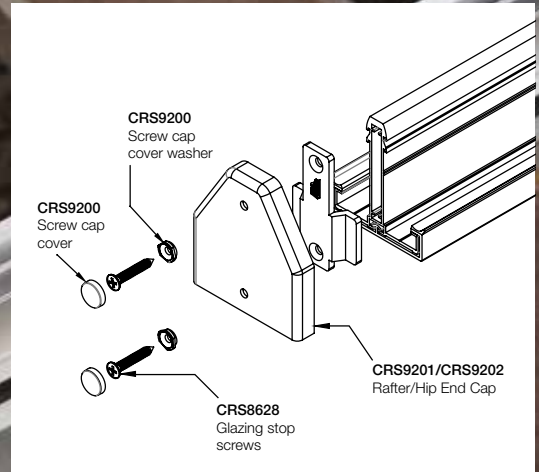

You can then proceed to loosely secure the side rafters to the ring beam using the threaded studs located down the ring beam.

NOTE: If access to the bar ends is limited, it is advisable to fit the glazing stops and end caps as shown (right) before fixing rafters to the ring beam.

FOR SKYPOD PLUS (ALUMINIUM RAFTER TOP CAPS) ONLY

2.5a

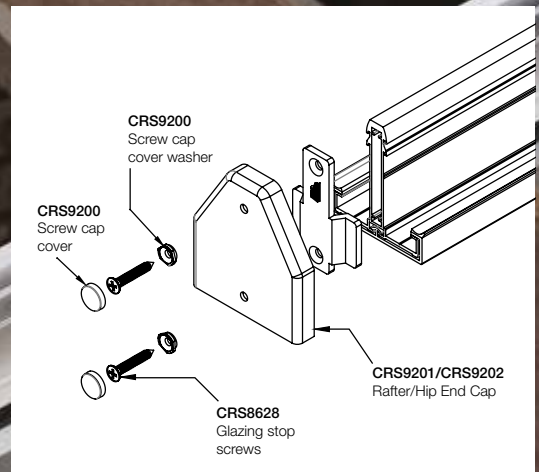

It is advisable to partially fit the glazing stops and end caps as shown (right) before fixing rafters to the ring beam. **Install the glazing stop screws to approx. half their length, do not install screw cap covers at this point.** You can then proceed to loosely secure the side rafters to the ring beam using the threaded studs located down the ring beam.

2.6



Supporting the ridge, the rafter bars can be secured to the ridge using the threaded studs. Once opposing rafters have been secured the ridge should be self supporting.

2.7



Using 2 x CRS8624S single studs, secure each hip to the spider casting. The body of the stud should locate between the retaining ribs on the lower casting face to stop the stud from spinning.

2.8

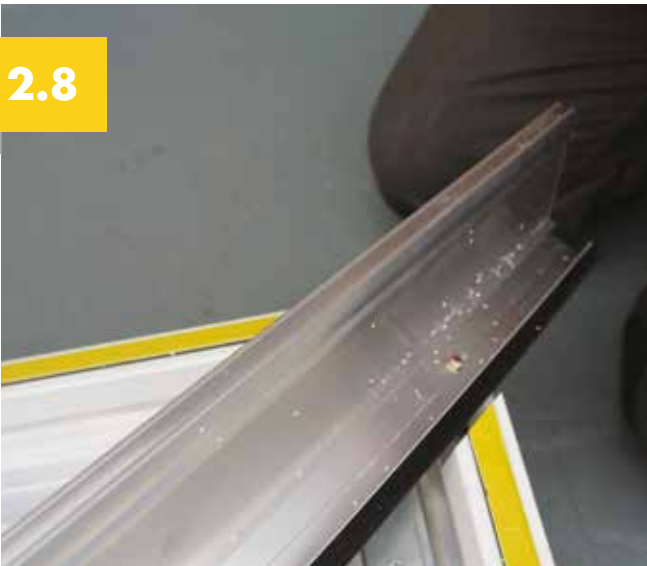

Locate the hips onto the external ring beam studs and loosely secure using fixing nuts.

2.9



Fasten the central rafters to the spider using 1 x CRS8625S double stud and nuts. If jack rafters are present, please refer to Section 3: Installing Jack Rafters on page 10.

2.10



If not already fitted, clip in the eaves beam seals between the rafters and hips using a nylon mallet. Check the rafters are all square to the ring beam and ridge, and then tighten all roof fixing nuts.

2.11



Locate the nylon bar through the spider and lock off using nuts and washers either side of the spider. The nylon bar should sit 5mm below the crest of the ridge profile.

2.12



Position the spider bottom cap and fix using the decorative boss onto nylon threaded bar. Note the nylon bar may require trimming down in length.

2.13

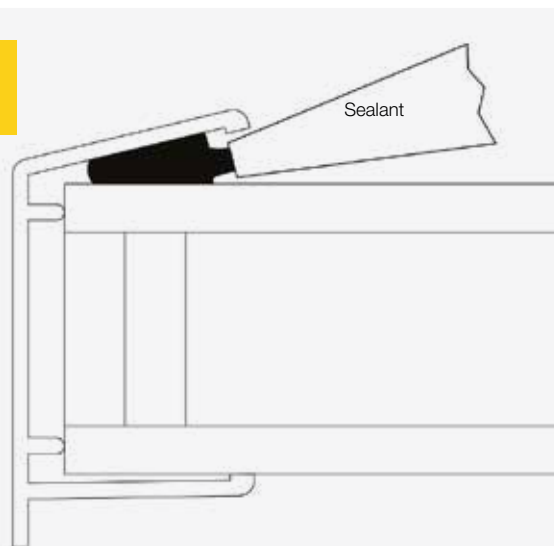

Fit the glazing end closures to the glass and run a bead of sealant between the profile and top pane of glass as shown above. **Only** use a suitable sealant with self cleaning glass. Soudal SMX 506 is recommended (available from Eurocell branches).

2.14

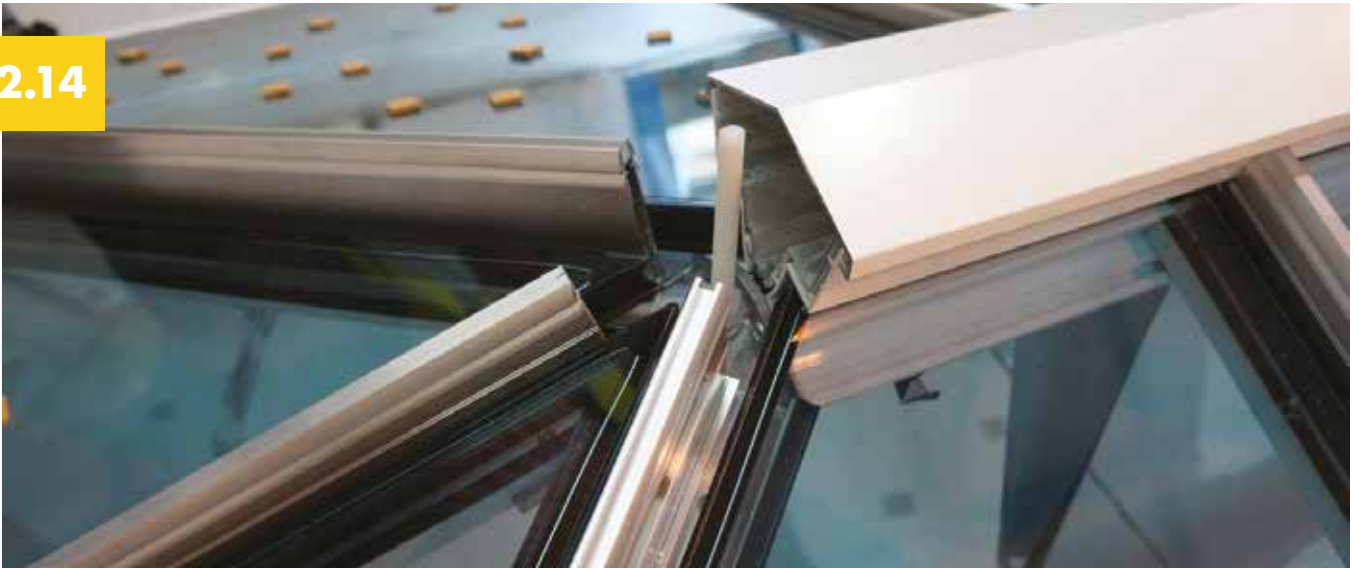

FOR SKYPOD (PVC-U RAFTER TOP CAPS).

If not already fitted, fit the glazing bar end caps and glazing stops. Then peel back two inches of eaves beam seal tape film and fold to the outside. Insert glazing unit ensuring equal coverage and ensuring the glass is resting onto the glazing stops.

2.15



Fit the foam bung and clamp plate and tighten M10 nut until the foam is firmly pressed down onto glazing.

FOR SKYPOD (PVC-U RAFTER TOP CAPS) ONLY

2.16

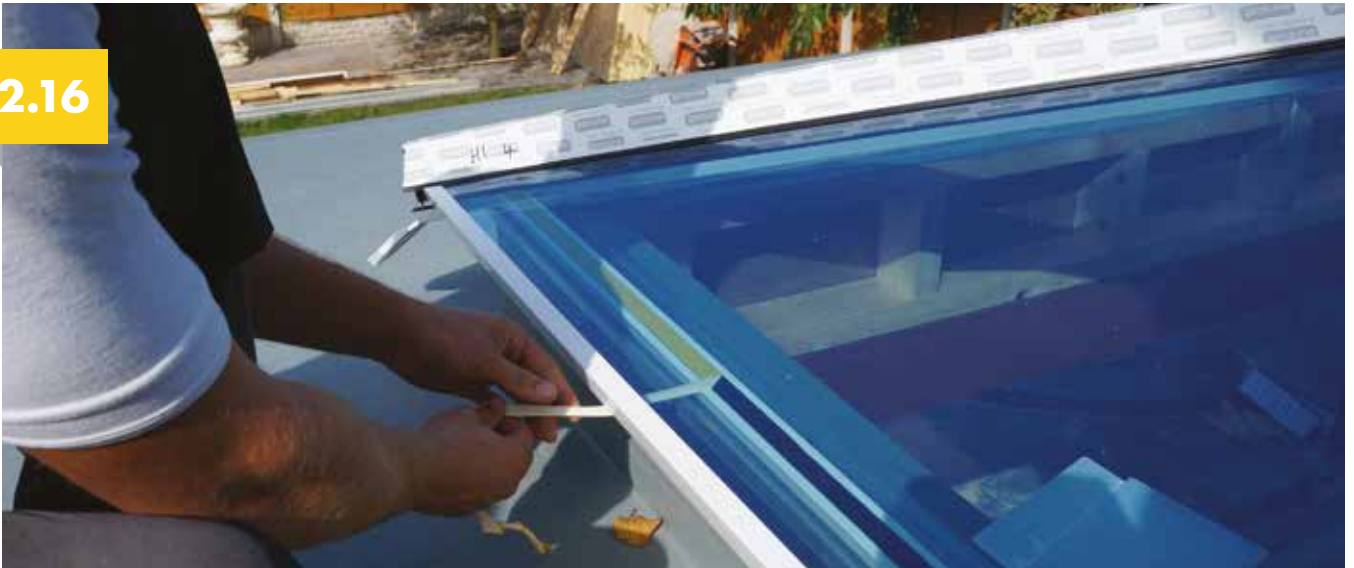

Fit the rafter and hip top caps using a nylon mallet, then ensuring the glass is positioned correctly, peel the remaining eaves beam seal tape film away and press glazing down to ensure contact with eaves tape.

FOR SKYPOD PLUS (ALUMINIUM RAFTER TOP CAPS) ONLY

2.16a



Ensure thermal breaks are installed on all glazing bars before attempting to install aluminium top caps. Do Not attempt to install the top caps with the thermal breaks with in the top cap as this will damage the top cap.

2.16b



Ensure Qlon gaskets are fully clipped into the top cap channels along the whole length of the top cap and are flush with the top and bottom of the capping, if they are long at the bottom they can be trimmed later. Position an adequately sized timber on top of the capping to spread the force, then use a nylon mallet to tap the capping down starting at the top and progressively working down the aluminium cap. Ensure the top cap is fully clipped down to the lower rafter barb, Qlon gasket should have good and equal compression along the whole length.

2.16c



Protective film can now be peeled off and then glazing stops plus end plus end caps fully tightened and secure.

2.17



Seal around perimeter of the foam bung where it intersects the ridge glazing seal, glass and glazing bar top caps.

2.18



Seal around rafter top caps to ridge glazing trim.

Only use suitable sealant with self-cleaning glass. We recommend Soudal SMX 506 (available from Eurocell branches)

2.19

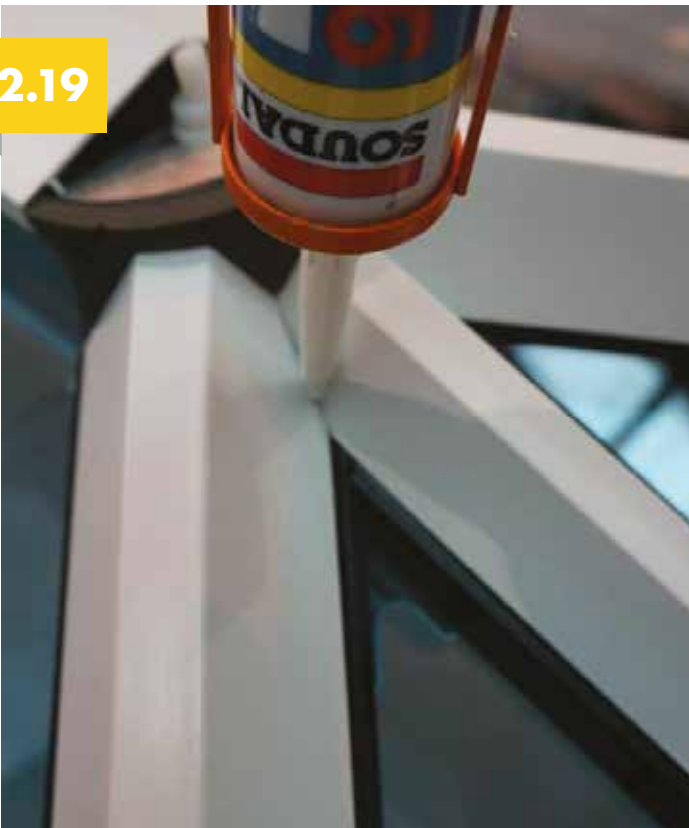

Seal the rafter top cap to hip top cap from the gasket intersection to foam bung.

2.20



Using a suitable high-grab adhesive sealant, run a small bead on the perimeter edges of the top cap and a larger bead further inboard as shown.

Recommended sealant is Soudal Fix All Crystal (available at Eurocell branches nationwide).

Note: Do not run the sealant to the bottom edge around the hip/rafter area to ensure the sealant does not touch the glass. Always ensure hands are cleaned as to not contaminate self cleaning glass.

2.21



Splay the top cap and lower onto the ridge whilst checking the capping is positioned correctly over the rafter and hip top caps. The capping returns should clip under the ridge profile when positioned correctly.

2.22



Ensure the capping is seated down correctly and remove any excess sealant from all edges.

3. INSTALLING JACK RAFTERS

3.1

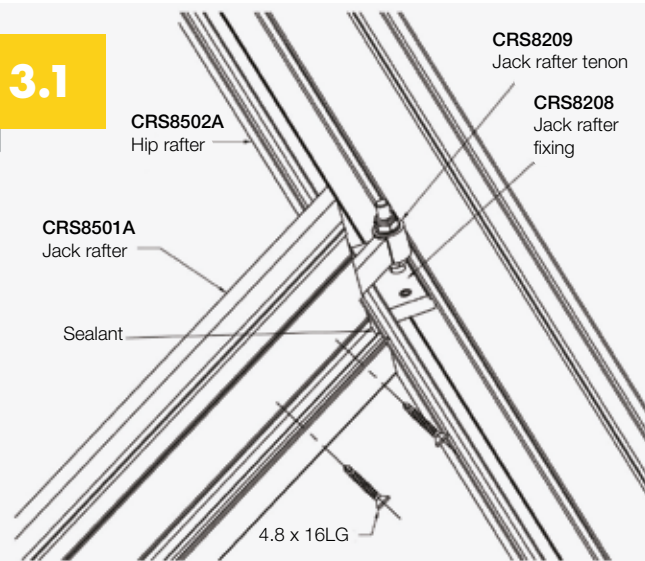

Locate the jack rafter tenon onto the jack rafter fixing bolt and adjust the lower nut to align gaskets, before tightening the the top nut.

Then seal the jack rafter internally to the hip.

3.2

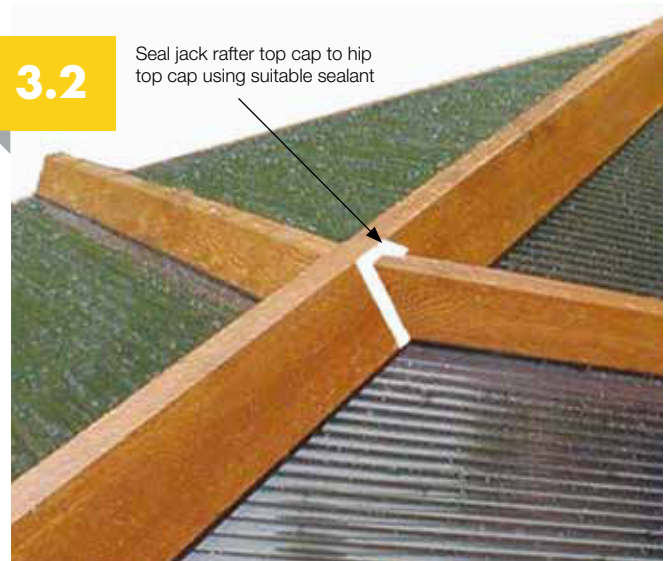

Seal jack top capping joints.

Only use suitable sealant with self-cleaning glass. We recommend Soudal SMX 506 (available from Eurocell branches).

4. INSTALLATION EXAMPLES

4.1





