

# syncro®

## INSTALLATION GUIDE



## CONTENTS

1. Surveying	3
2. Removing the framework	4
3. Preparation of aperture	6
4. Fitting the new frame	8
5. Fitting the glazing	14

### If in doubt at any stage

Please contact Technical for any technical support or advice



**0333 321 2353**



Installation video available  
on Eurocell's YouTube page

# INSTALLATION GUIDE

## TRANSPORTATION AND HANDLING OF DOORS

- ▶ Doors can be transported either glazed or unglazed. Depending on weight it is important that when the doors are in transit they are in position. To prevent movement and surface scratching by wedging flexible packing material between surfaces.
- ▶ Prior to fitting on site doors must be checked for imperfections and damage. The majority of building materials (i.e. sand, cement) will not affect the properties of the PVC-U. However, solvent-based materials - Bitumen etc - that can be found on building sites will stain white PVC-U.
- ▶ It is recommended that PVC-U doors delivered in a fully fabricated state should retain the protective film until all building work has ceased.



# 1. SURVEYING

- ▶ Good surveying is essential to ensure a trouble free successful installation, also to avoid costly remakes caused by incorrect measuring.
- ▶ When surveying it is the surveyor's responsibility to determine that the structural openings and surrounding areas are in a state of good repair and provide the correct dimensions for manufacture.
- ▶ It is not possible to provide full comprehensive surveying instruction to cover every eventuality, the following basic notes are for on-site surveying guidelines.



## FOR ALL CONFIGURATIONS OF DOOR CARRY OUT THE FOLLOWING:

1. Check the brickwork around the opening for any defects.
2. Check if any provision needs to be made for telephone or TV cables. Advise the customer of these facts before proceeding.
3. Take several measurements across the opening to find the narrowest point, having taken care to measure beyond any existing sub-frame or packing. Deduct 10mm from this dimension to give the finished width. (5mm allowance for expansion on each side).
4. Measure the height of the opening in the same way as detailed above and deduct 10mm for expansion.
5. Take a note of any existing cill and establish if this is to be included in the overall frame dimension (eg. stone cill).

If the cill is to be replaced take a note of the depth of the existing reveal and determine which cill is most appropriate (i.e. 180mm, 150mm or the 85mm cill).

6. Check the opening is square – it is important that the diagonals are no more than 10mm different, if they are then remedial work may need to be carried out on the brickwork to ensure the opening is square.
7. If the door is fitted deep into the reveal check to see if the extension blocks are necessary to ensure that the sash operates and is not impeded.
8. If the customer has chosen a style of door, the surveyor must check to see if the styles are suitable for the intended application.

### Surveyor must check:

- a) That the units are within the supplier's specification.
  - b) That the units are within the max/min size limitations.
  - c) That the doors will perform as designed.
  - d) That the doors are acceptable to the customer.
  - e) That all doors meet the requirements of current legislation.
9. The responsibility for re-plastering, fitting of curtain rails, blinds or other fittings or fixtures must be discussed and agreed with customer.

## 2. REMOVING THE FRAMEWORK

2.1



On arrival, before removing any existing door frames, check that the replacement frames size is the same as the existing door frames. When checking the sizes, ensure that the new frame has a 5mm expansion gap around the perimeter.

2.2



Once you're sure your measurements are correct, proceed to remove the old door frames.

2.3



Remove as much glazing as possible, this will help to reduce the weight and allow easier handling.

2.4



Run a sharp blade around the inside perimeter of the door to break the bond between frame and the plaster. This will also minimise the damage to any interior decoration.

**2.5**



Remove old fixings and break the external silicone seal with a blade.

**2.6**



After the removal of the frame, remove all sealant and debris from the brick work.

**2.7**



Check that mortar bed has sufficient clearance, if not remove it.

### 3. PREPARATION OF APERTURE



#### GENERAL PREPARATION

Before removing the existing door the replacement frame should be measured and tolerances checked against the aperture (i.e. 5mm on either side of the door and 5mm on the top and bottom). Doors should be installed plumb and square without twist, racking or distortion of any member to ensure that they operate correctly after installation. Eurocell door frames should be manufactured accurately to the specified outer frame dimensions and have opening lights to fixed frame clearance for operational efficiency.

Distortion of any frame or sash member will reduce performance and create a security risk. The choice of fixing cleats or plastic sheathed fixing bolts is usually dependent on whether the opening is already plastered. Fixing bolts are sometimes preferred to minimise redecoration in existing houses where doors are being replaced. Both methods are suitable for new installations.

Prior to installing new Patio measure the distance from the internal face of the plaster to the face of the external brick. The 20mm step in the outerframe is to help accommodate internal plaster but in some cases it may need cutting back to accommodate to Patio Frame.

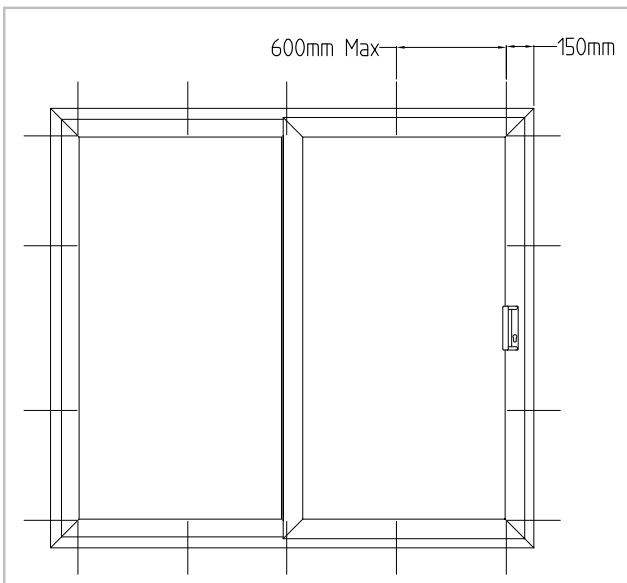
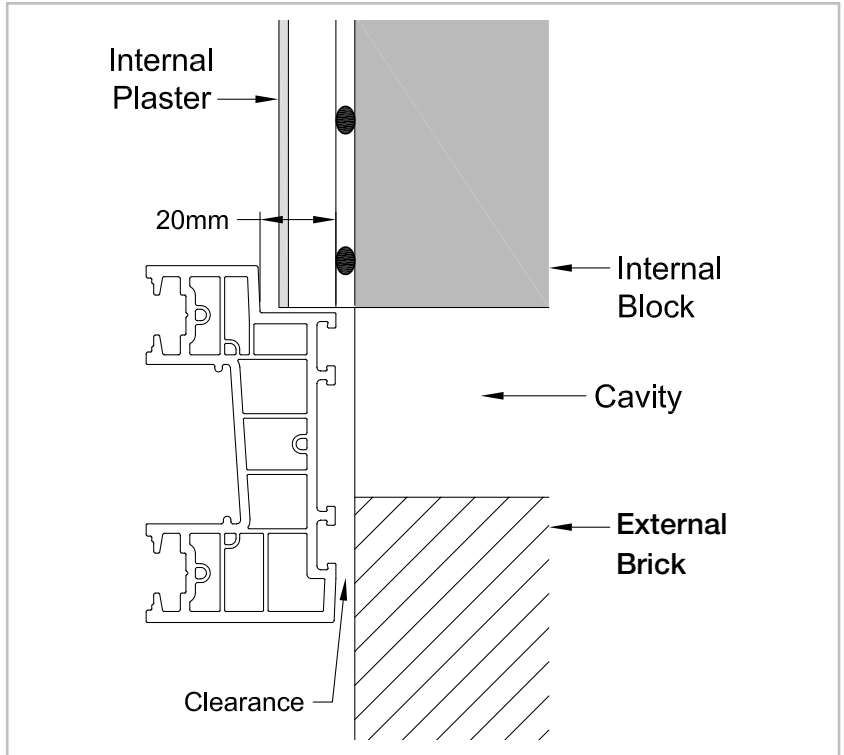

If fixing cleats is the chosen method of installation they should be attached to the outer frame starting at 150mm from the corner and thereafter at a maximum of 600mm centres. The cleats should be screwed into the mainframe in the central reinforcing chamber.

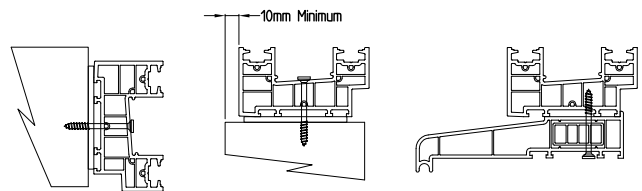

## CILLS

Cills AC180, AC150, AS85 should normally be fixed to the bottom edge of the mainframe prior to installation of the door. The fixing screws should penetrate upwards into the reinforcement section in the central chamber. The cill should be placed on to a bed of mortar or silicone sealant.

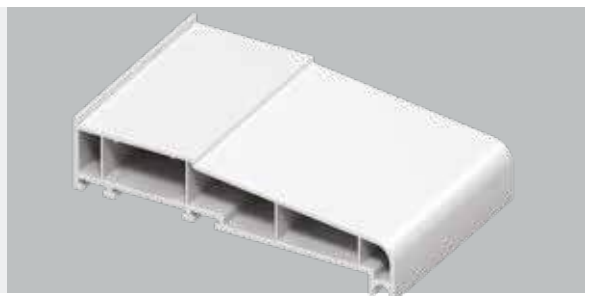

## 4. FITTING THE NEW FRAME

4.1



Remove the end stops.

4.2



Remove all covers to allow for frame fixings; tops, bottom and sides.

4.3



Put 2 lines of bed mastic to the base (front and back) to create a water tight seal to the base of the door.

4.4



Pack the doors to keep it square and centralising the frame in the aperture and ensure it is level and square.

**4.5**



Open closing sash, mark 150mm from each corner of frame and at 600mm intermediate positions.

**4.6**



Drill clearance hole for relevant fixing.

**4.7**



Check frame is plumb and level before any fixing.

**4.8**



Remove screws from fixed sash and slide back away from frame.

4.9



Slide sash across to allow for fixing frame other side, same as mentioned on previous page.

4.10



Keep head trim in place with sashes already in position to fix head.

4.11



Peel trim down to fix underneath and then clip back into position.

4.12



Slide sash back across and fix sash to frame.

4.13



Peel trim down from slider head and fix other side.

4.14



Slide in on an angle so the foot positions under the pip and clip the outside into position. You will hear a click when fitted correctly.

4.15



The long leg of the trim goes to the outside to allow for a flat finish.

4.16



Mark position (again 150mm from the bottom corner, and the in 400mm increments) the bottom fixings into the base.

4.17



If the base is aluminium low threshold, be careful not to damage the thermal break. To ensure this doesn't happen, drill just behind the thermal break.

4.18



Clean debris and dust before finishing.

4.19



Mastic in the hole to seal the head of the screw.

4.20



Fit all trims back in position.

4.21



Put the end stops back in place.

## 5. FITTING THE GLAZING

5.1



Remove the beads to allow for glazing. Mark each bead with location to make refitting easier.

5.2



Lift the glass using a glass lifter, position lifter in centre of pane. Allow a slight angle on interlock side when offering up into position.

5.3



Pack glass to suit and put top/bottom beads into position first and then the sides.

5.4



When putting the beads back in – tap from the sides to the middle to ensure the bead is tight into each corner, using a nylon head mallet.

**5.5**



Pack around the glass to ensure it is centralised and square.

**5.6**



Adjustment – once the door is set, check to make sure the sash is square on the track. Use an allen key for adjustment of up and down movement if necessary.

**5.7**



Check the operation for a perfect gap at the top and bottom of the frame.

**5.8**



When 100% happy that the door is set, position the interlock covers in place. Tap the back in first down the length then tap down the front face.

5.9



Head cover to be positioned last.

5.10



Position the cill cover/low threshold cover.

5.11



Cut off the packers flush to the frame.

5.12

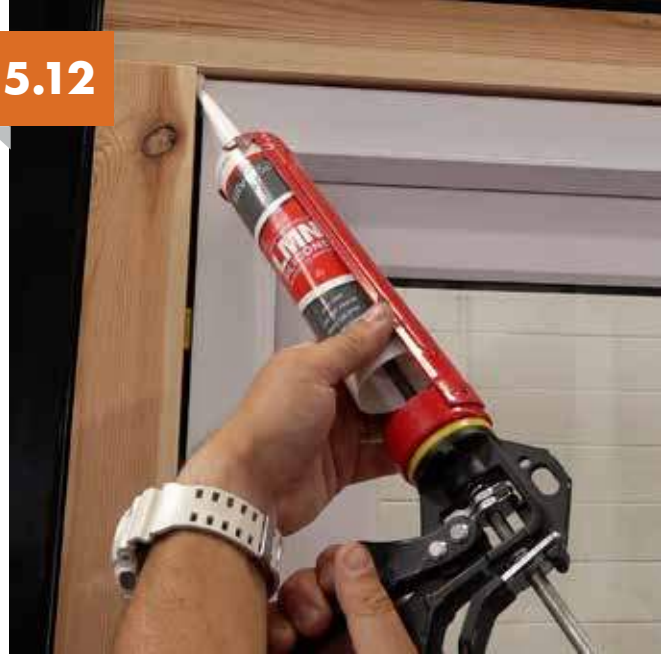

Silicone sealant using a low modulus sealant to finish around the frame.

## 5.13



Where soft close is part of the door structure, this will be built at the fabrication stage and has no installation required.

## FINISHING OFF

BEFORE



AFTER

If desired, the soft close actuator can be covered, so that it is no longer visible. To do this you can fit a cloaking fillet C30 trim or similar to the head of the frame, from width to cover.

## ALSO AVAILABLE

Visit [eurocell.co.uk](https://eurocell.co.uk) to find more installation guides and installation videos for Eurocell products.

