

UNIFOLD

Bi-fold Door Installation Guide

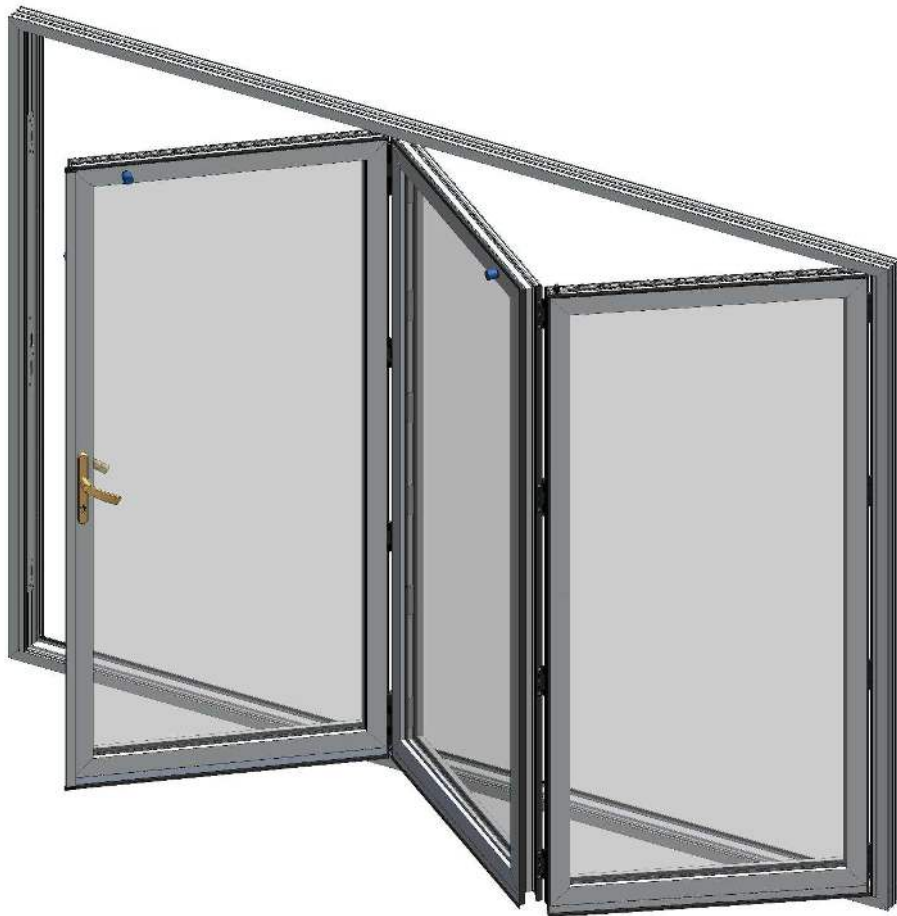

INDEX

1. GENERAL INSTALLATION INSTRUCTIONS.....	3
2. RECOMMENDED TOOL LIST.....	4
3. SITE SURVEY.....	5
• Opening inspection.....	5
• Internal finished floor level and datum line position.....	5
• Aperture height inspection using datum line.....	6
• Jamb inspection.....	6
4. SUB SILL INSTALLATION.....	7
• Sub sill installation.....	7
5. FRAME ASSEMBLY AND INSTALLATION.....	8
• Outer frame assembly.....	8
• Low threshold assembly.....	9
• Outer frame installation.....	10
6. ADJUSTABLE JAMB INSTALLATION.....	11
7. DOOR LEAF INSTALLATION.....	12
• General installation recommendations.....	12
• Panel No.1 installation.....	12
• Panel No.2 installation.....	13
• Panel No.3 installation.....	14
• Sliding post installation.....	15
8. GLAZING INSTRUCTIONS.....	16
9. OPERATION CHECKING AND ADJUSTMENT.....	17
• Door unit operation inspection.....	17
• Overall gap size inspection.....	17
• Master door adjustment.....	18
• Width adjustment using adjustable jambs.....	18
• Securing hinges with final fixing screws.....	19
• Weather seal application.....	19
• Panel catch installation.....	20
10. FINISHING TOUCHES.....	21
11. OPERATION AND MAINTENANCE.....	21
• Opening and closing operation for bi-folding door with swinging door.....	21
• Opening and closing operation for bi-folding door without swinging door.....	21
• Maintenance recommendations.....	21

GENERAL INSTALLATION INSTRUCTIONS

1. ASSEMBLY INSTRUCTIONS

IMPORTANT. Read these assembly instructions before beginning any installation work. Install as recommended otherwise the door unit may not function properly and any warranty, written or implied, will be void.

2. QUALIFICATIONS

The assembly instructions are only for the attention of qualified installers who are trained and qualified in window and doors installation techniques, and are aware of the manufacturer's recommendations for the system used.

3. TRANSPORT AND STORAGE

Parts that could come lose during transportation can be damaged or cause accidents.

All packaging opened to allow the goods to be inspected must be closed and properly sealed for further transport.

Any goods that will be further transported must be loaded safely and securely.

4. INCOMING GOODS

All goods received must be inspected for any transport damage prior to being removed from the vehicle. The goods received must match the delivery note.

Any wet packaging may cause damage to the goods, and therefore must be removed immediately.

5. SITE SURVEY

It is important to check the conditions on site before starting the assembly.

- Check for any apparent defects and deficiencies around the structural opening. If any defects are found, then the customer must be notified, and agreement reached as to who is responsible for rectifying these defects prior to the new window/door installation.
- Check structural conditions such as the wall construction, the load capacity or adhesiveness of the edges for adhesive sealing systems, evenness, building moisture, a possibility for load transfer and mounting, constructional tolerances and height reference points.
- Check for contractual agreements, supplied assembly detail, planning guidelines, heat protection, humidity proofing, and interferences to other assembly sections.

ATTENTION! *The fixing materials are not part of the scope of supply. The installer must decide on which fixing materials to use after assessing the given substructure. If any supplied fixing materials are used, Debar do not accept liability for the correct assembly. The installer must ensure that the fixing materials are suitable for the respective substructure and that assembly is completed correctly.*

6. HANDOVER

All operating, assembly and adjustment instructions as well as maintenance and care guidelines must be delivered to the user when briefing them. It is essential to train the user on the function of the supplied product and provide instruction on the directions for safety and use. Incorrect operation or failure to observe the instructions may lead to damage and accidents. The customer must store the instructions carefully and hand them over to the new owner in the event of sale.

RECOMMENDED TOOLS

- Appropriate fixings into structural opening.
- Mixed selection of frame packers.
- Mixed selection of glazing packers.
- Rubber mallet or plastic mallet
- Set of HSS drill bits.
- Drill / SDS hammer drill.
- Saw for cutting aluminium sill.
- Long spirit level
- String line
- Tape measure
- No.2 Pozi drive
- 2.5mm; 3mm; 4mm Allen keys.
- Level or Laser Level
- Gloves
- Vacuum Cups
- Caulk Gun and Low modulus Silicone
- Paper Towels
- Utility Knife
- Silicone and gun.
- Set Square.
- Tressels x4

SITE SURVEY

Opening inspection

- The aperture for the new doors must be flat, level, straight, plumb and square at every single side. There should be a solid structure to fix the frame.
- The aperture load bearings must not be transferred to any part of the frame when fitted.
- Prepare the aperture by making sure it is clean.
- Remove any old silicone and brush down the threshold.
- The internal and external reveal sizes should be checked and any variations must be determined to ensure enough opening light for the area where doors will fold and will not be obstructed by plaster, tiles or etc.
- Check the aperture’s height, width and diagonals to ensure the opening is equal on all sides and square.
- Generally three measurements should be taken.

NOTE: - The smallest measurement of width and height used to determine manufacturing sizes.

- See Also Section “Aperture height using laser level.

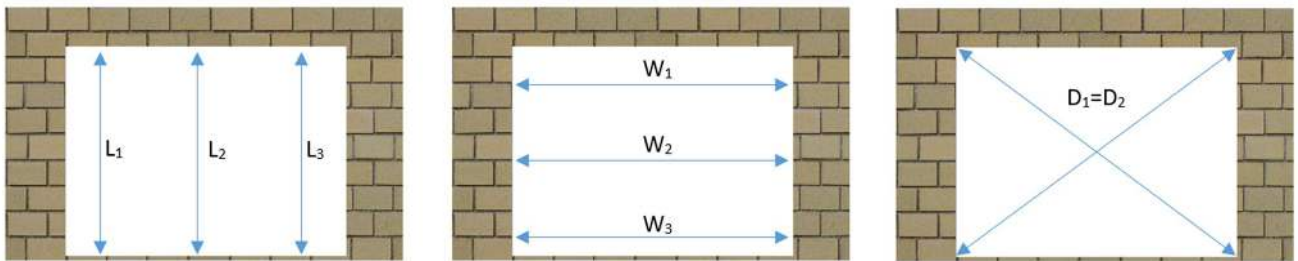

- Use tape measure to verify the aperture overall height and width. At least three measurements must be taken.
- Smallest height and width measurement will determine the overall frame manufacturing size.
- By measuring the diagonals verify the aperture is square.

Internal finished floor level and datum line position

- Select a point within the agreed/existing structure finished floor level from where the builder can after determine the internal floor level i.e. tiles, carpet, timber.
- Using laser measure set a datum line at 1000mm from the existing finished floor level.
- Take into account the agreed internal floor finish i.e. tiles, carpet, timber.
- Mark the datum line on each jamb of the aperture.

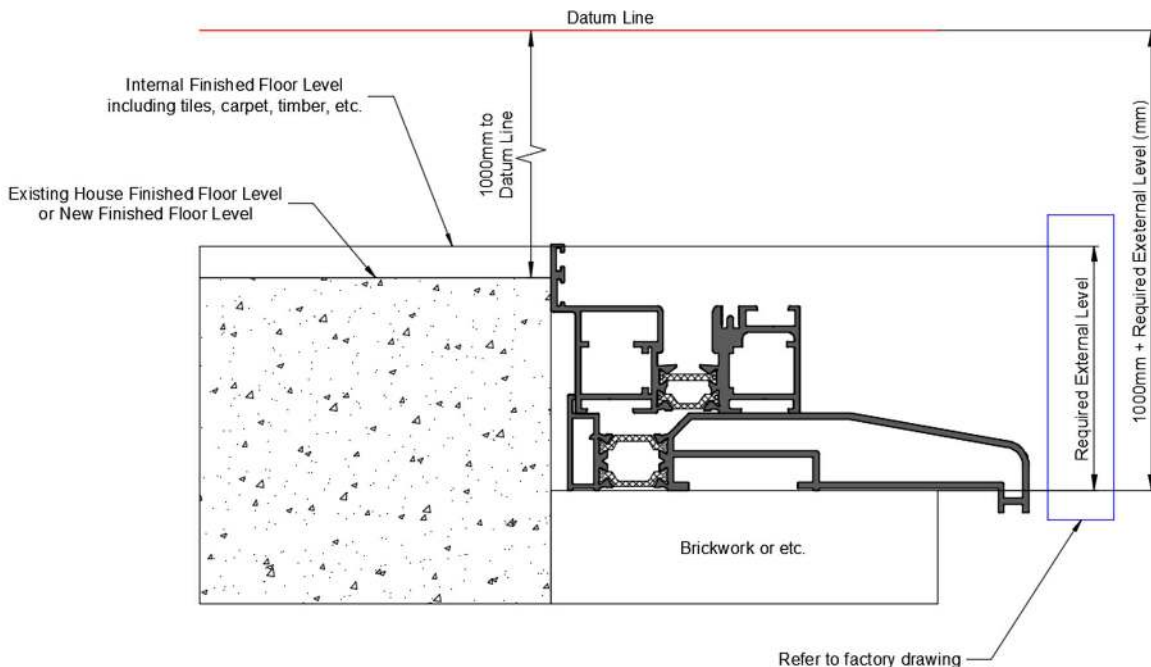

- Refer to the factory drawing and specify which threshold profile or sub-sill is required.
- Check if the existing threshold needs to be lowered taking into account if the internal edge of the aluminium threshold sits flush, or is set at a certain height with the new internal finished floor level.

Aperture height inspection using datum line

- From the laser datum line measure the distance to the threshold at left, centre and right positions where new bi-fold door will sit on.
- Each of the bottom measurements should be uniform. If not then the threshold is not level and structure should be leveled.
- From the original datum line position (set at 1000mm) measure the distance to the top underside of the aperture at left, centre and right positions.
- Each of the top measurements should be uniform. If not then aperture at the top is not level and the adjustment to the manufacturing height of the frame must be made.

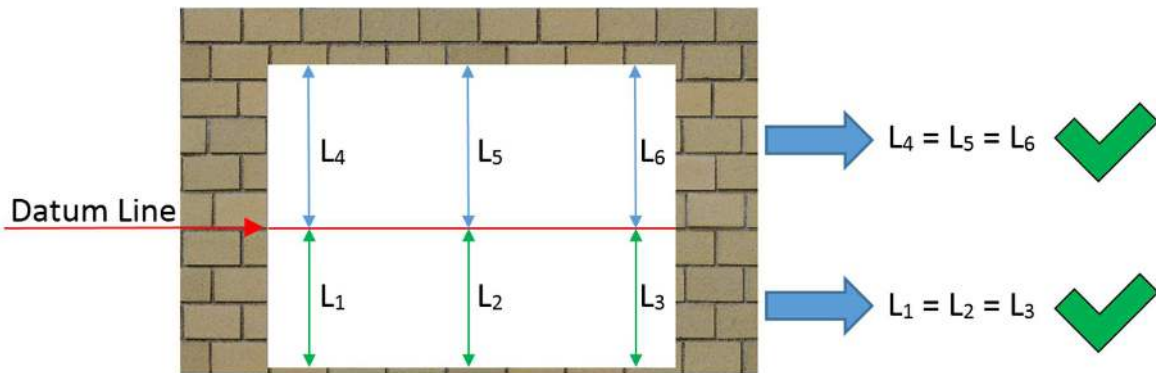

Jamb Inspection

- Set a vertical laser datum line position at 250mm from the jamb.
- Take measurements from top, middle and bottom of the laser line to the face of the jamb.
- Each horizontal measurements should be equal. If not, then the jamb is not plumb and adjustment to the manufacturing frame width must be made.
- Repeat jamb inspection for the opposing side.

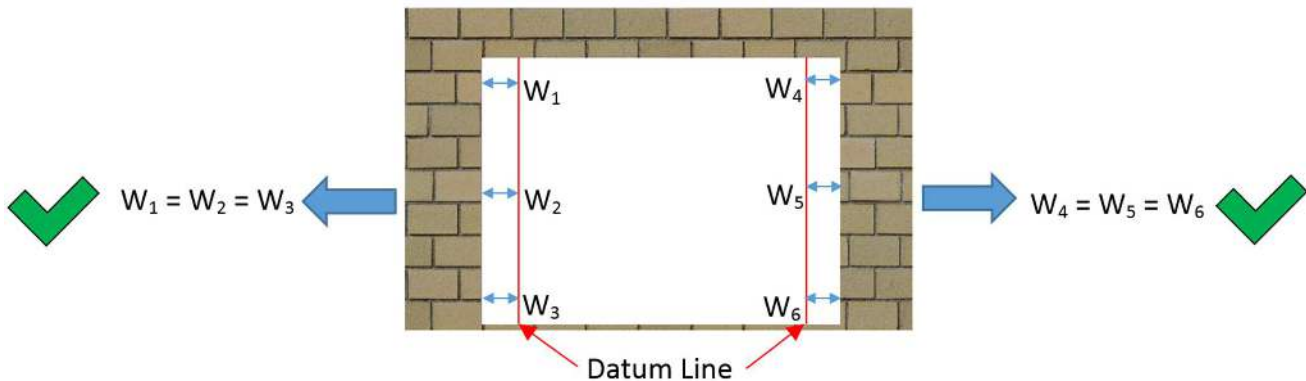

Manufacturing sizes

- Allow the aperture to be 10-15 mm wider and 10-15 mm higher than the overall frame size of the ordered unit. It is important that the opening size for new frame is correct.

NOTE: - Overall height of new unit is measured from the bottom of the sill and not from the finished floor.

SUB SILL INSTALLATION

- The need for any sub-sill should be determined at the beginning of the project.
- The size of the sub-sill should be as such that there is an overhang of at least 25 mm from the face of the building.
- The installer should determine how the sub-sill should be fitted, taking into account features such as horns.

Sub sill installation

NOTE: - Check the sill for drainage slots, make sure they are clean and not blocked by any debris, clean if necessary.

- Using low modulus silicone seal the ends of the sill section.
- Install the end caps (ref DBA1-203N) as shown below.

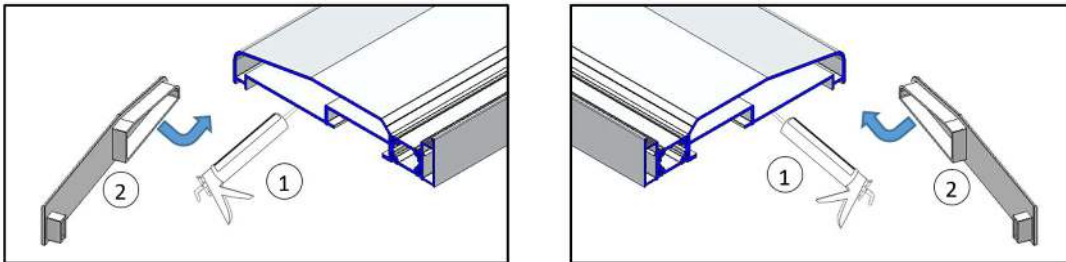

- Place the sub-sill on to the aperture.
- Use a spirit/laser level or a string line to assess the level of the sub-sill.
- Temporarily place the required packers under the sill, check the level and adjust if necessary

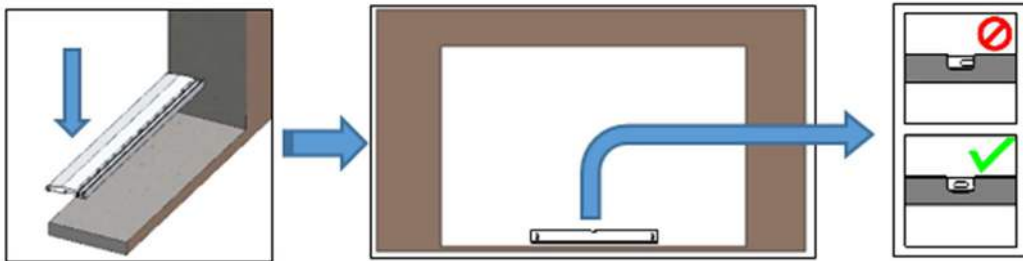

- Use specified fixings to fix the sill through the thermal break at minimum 150mm from each end, and spacing every 500mm centres.
- Fill each fixing hole with low modulus silicone before inserting the fixing.

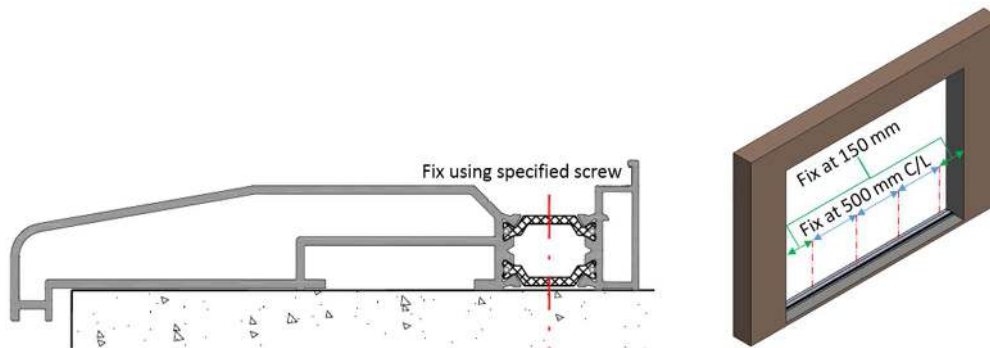

- Double check for level and adjust if necessary.



FRAME ASSEMBLY AND INSTALLATION

Outer frame assembly

- Apply low modulus silicone at all outer frame connection joints and between the frame components.

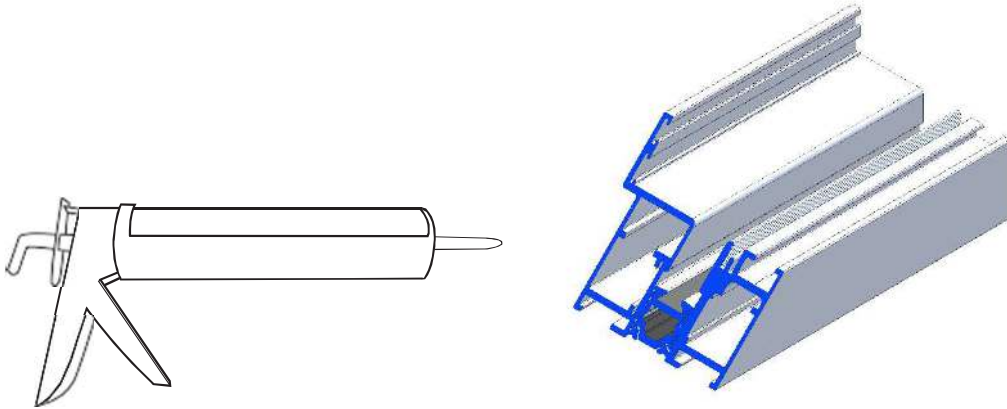

- Connect the outer frame corners using outer cleats and M6x16 machine screws as shown below.
- Align the frame by adjusting the screws, if necessary.
- Any silicone excess should be wiped off at this stage.

TOOL REQUIREMENT: - 4mm Allen key is required.

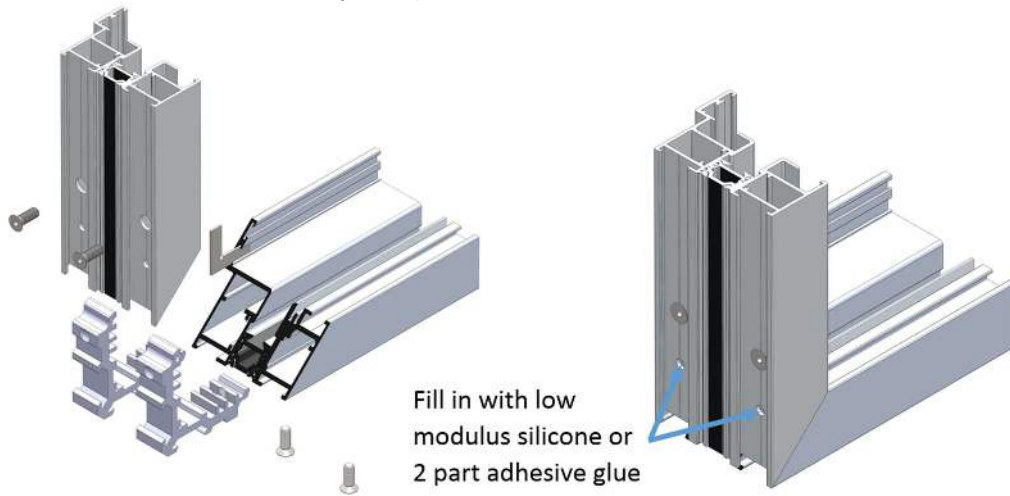

- Repeat same process to all four outer frame corners.

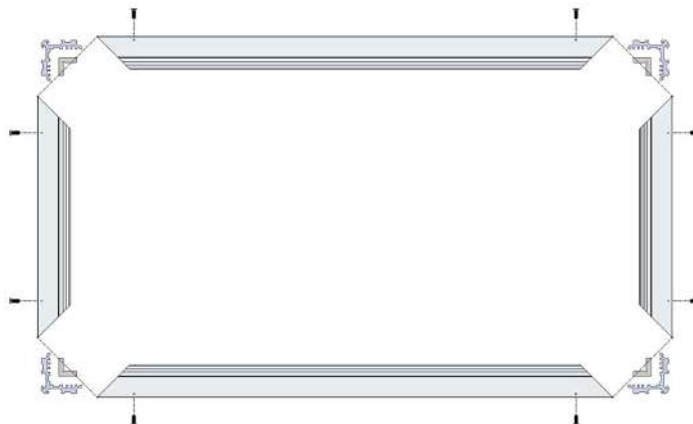

Low threshold assembly

- Apply low modulus silicone to all frame connection joints and between the frame components.
- Use low threshold fixing kit (ref. DBA1-105) to join the corner as shown below.

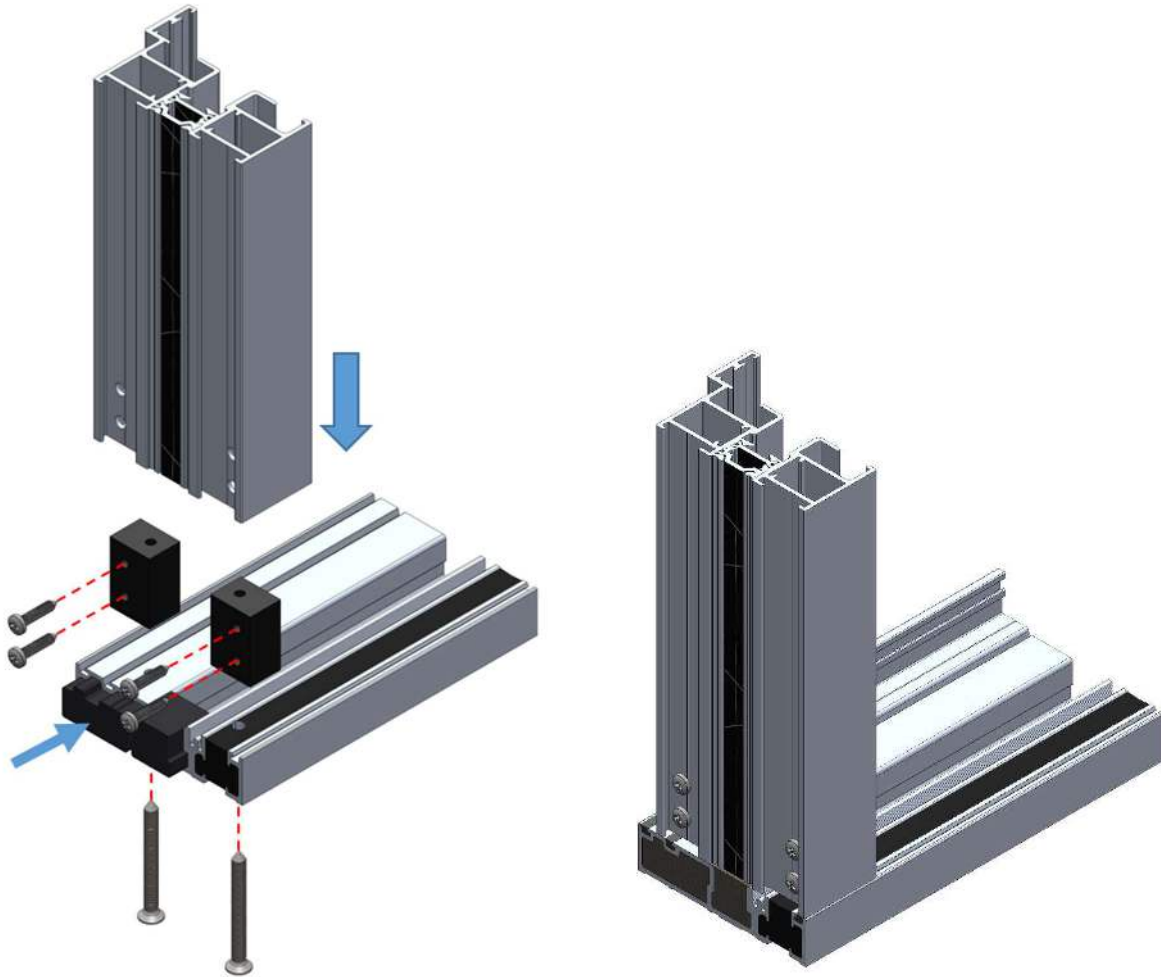

- Align the frame by adjusting the screws, if necessary.
- Any silicone excess should be wiped off at this stage.
- Ensure no water can escape from the low threshold past the jambs.

Outer frame installation

- Insert the frame into prepared structural opening and pack as necessary to ensure that the frame is held plumb and square inside the opening.

NOTE: - If sub-sill installed. Run a silicone bead along the sub-sill rebate to ensure weather tight joint.



- Pack out all fixing points to ensure tight and supported fixings.
- Secure frame using suitable fixing screws and plugs.
 - A = Anchor distance from corner of frame approximately 150mm.
 - B = Anchor spacing generally at maximum 500 mm.
- Ensure the top and bottom frame remain plumb and square over the complete length.

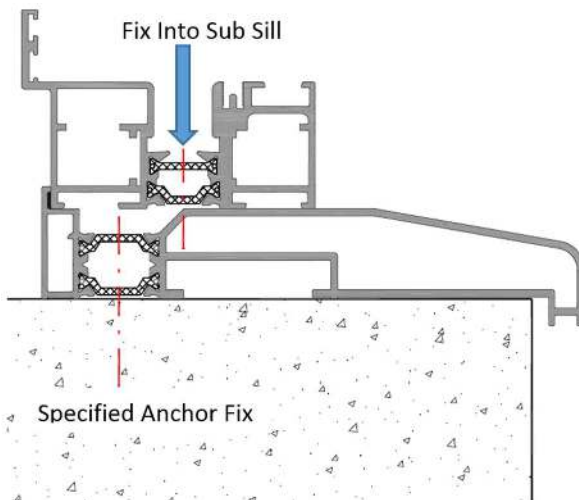
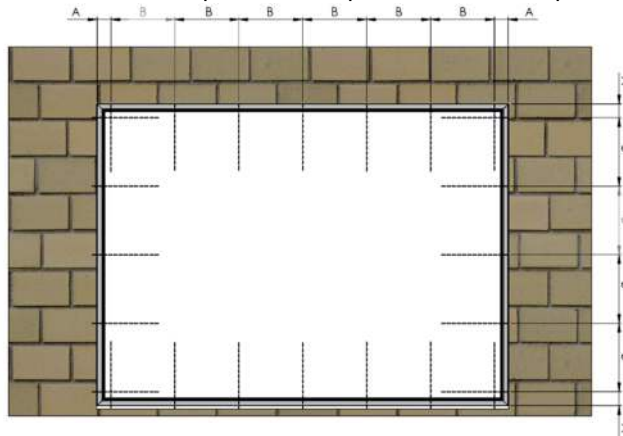

Typical outer frame installation with sub-sill

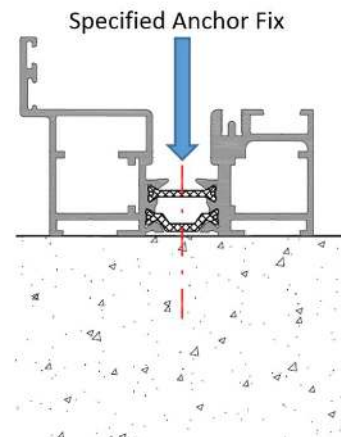

Typical outer frame installation

- Check the level and make sure that the frame is set plumb and square.
- Using low modulus silicone ensure that the perimeter is sealed against water penetration at both inside and outside of the opening.

- Clean away all debris from bottom rail, especially guide channel.

ADJUSTABLE JAMB INSTALLATION

- Remove any weather seals or rebate profiles attached to adjustable jamb.
- Set all grub screws flush with back wall of the adjustable jamb.
- Fit the adjustable jamb profile into outer frame up to the end.

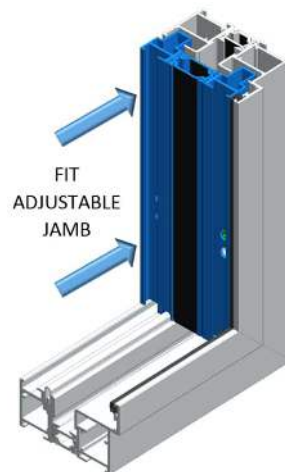
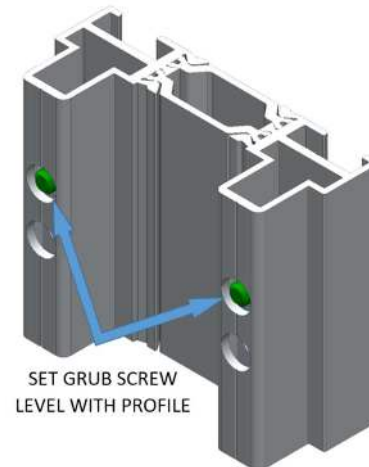

- Use factory pre-drilled holes at adjustable jamb profile and drill $\varnothing 4.0\text{mm}$ pilot holes in the outer frame for self-tapping fixing screws.
- Fix the adjustable jamb in place using $\varnothing 4.8 \times 48\text{mm}$ self-tapping screw.

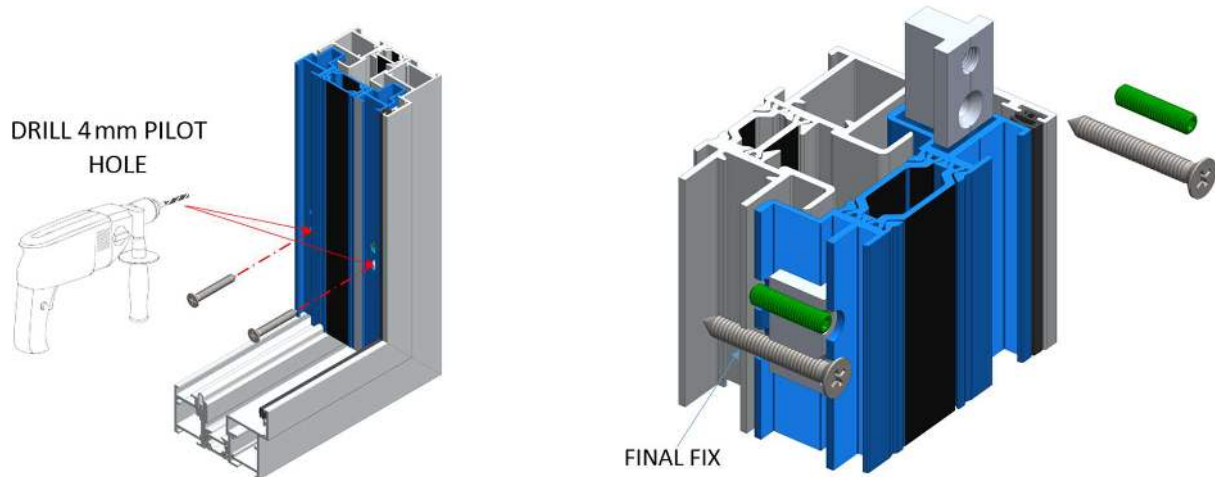

DOOR LEAF INSTALLATION

General installation recommendations

- Before installing any door panels check for all the components. Make sure there is no missing components.
- Look for the panel glass beads to determine the interior side.
- Look for the panel drainage holes to determine the bottom side.
- All panels are numbered and must be installed with accordance to the factory drawing.

Panel No.1 Installation

- Align the side of panel No.1 that has clamping plates on with hinges attached to outer frame adjustable jamb.

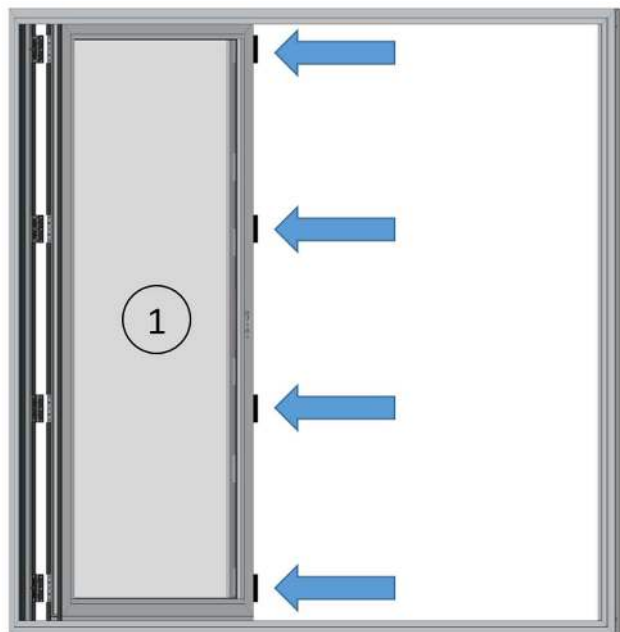

- Locate the hinge leaf over the clamping plate and secure with M5x10mm machine screws using top and bottom countersunk hinge holes.

TOOL REQUIREMENT: - 3mm Allen key is required.

NOTE: - Do not use 4.2x25mm self drilling screws at this point.

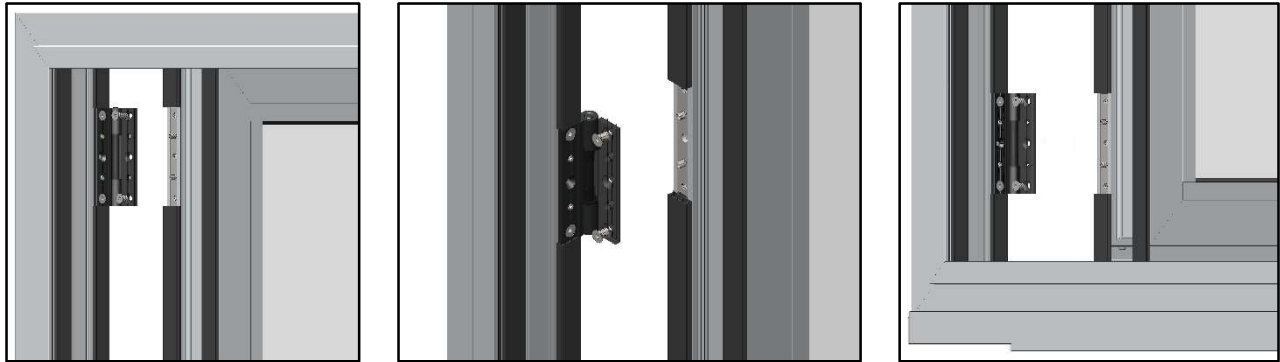

Panel No.2 Installation

- Slightly lean panel No.2 and fit the bottom roller guides into middle channel of the bottom track.
- Align the top guides of panel No.2 and fit them into middle channel at the top.

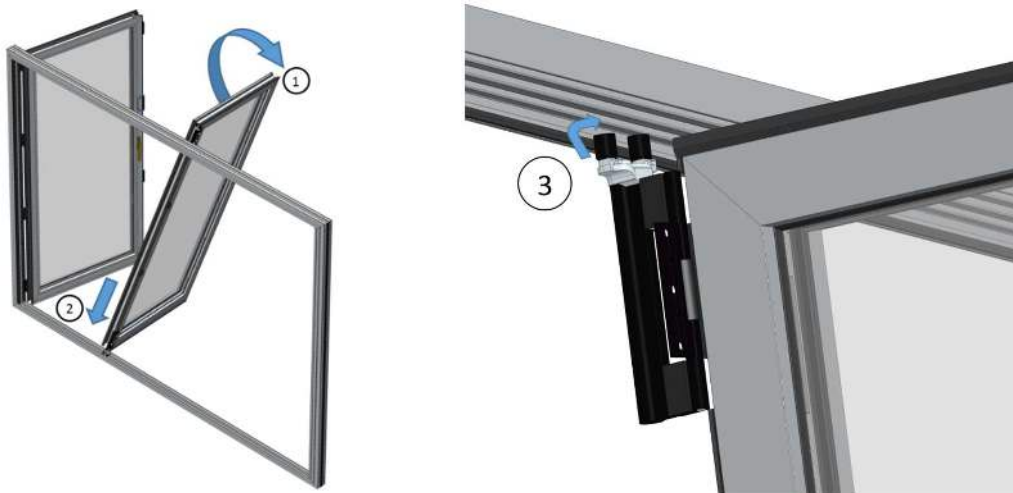

- Slide panel No.2 to align clamping plates with hinges attached to the first panel.
- Keep both doors on an angle for better access to hinges.

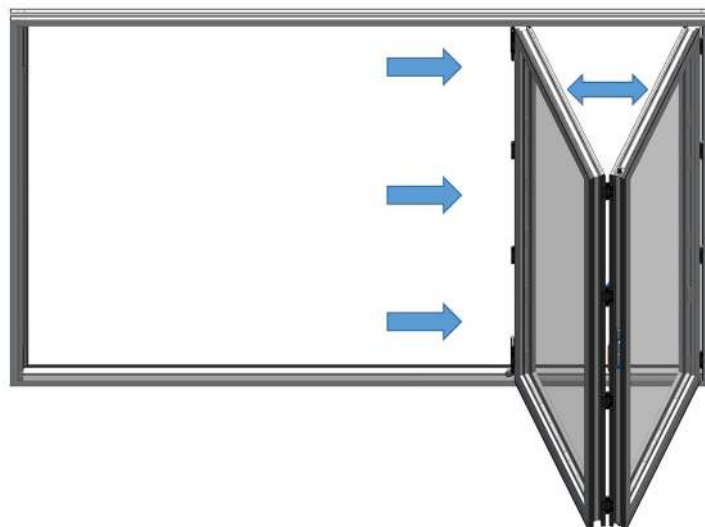

- Locate the hinge leaf over the fixing plate and secure with M5x10mm machine screws at top and bottom holes.

TOOL REQUIREMENT: - 3mm Allen key is required.

NOTE: - Do not use 4.2x25mm self drilling screws at this point.

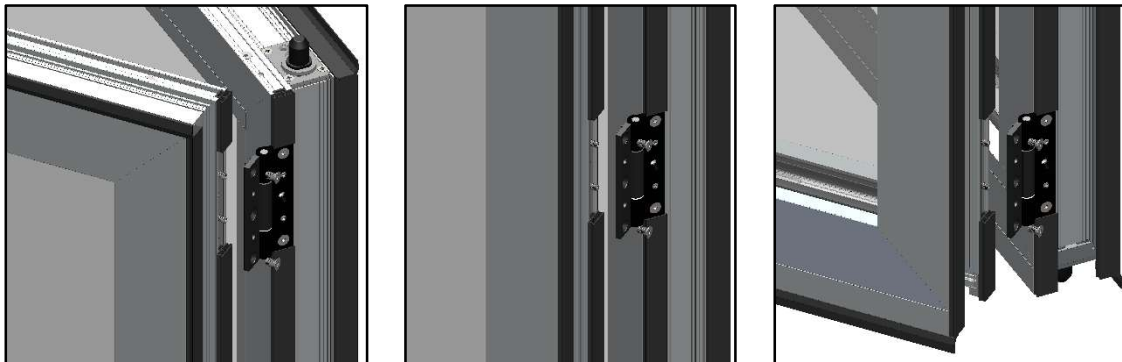

Panel No.3 Installation

- Lock first two panel doors together before installing door No.3.



- Align panel No.3 clamping plates with hinges attached to second panel.

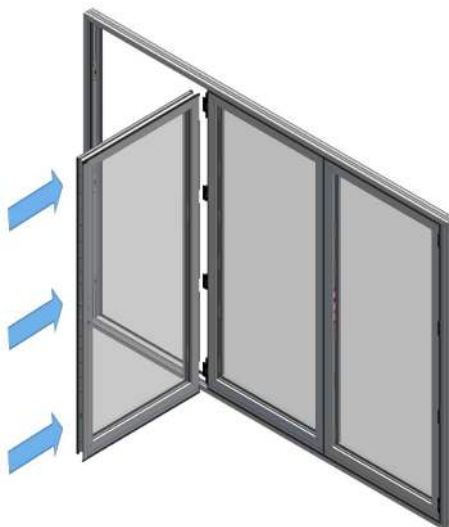

- Locate the hinge leaf over the fixing plate and secure with M5x10mm machine screws at top and bottom position.

TOOL REQUIREMENT: - 3mm Allen key is required.

NOTE: - Do not use 4.2x25mm self drilling screws at this point.

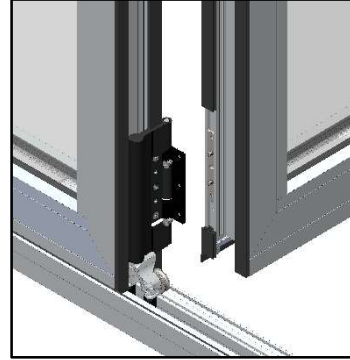
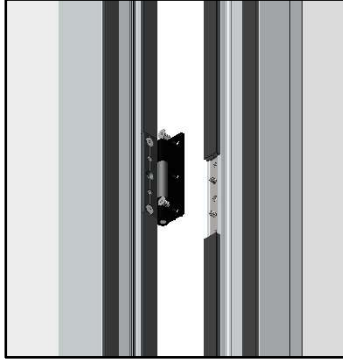

Sliding post installation

- Open the sliding post attached to the door panel as shown below.



- Slightly lean the panel with sliding post and fit the bottom roller guides into middle channel of the bottom track.
- Align the top guides of panel with sliding post and fit them into middle channel at the top.
- Slide the panel to align clamping plates with hinges attached to the first panel.
- Keep both doors on an angle for better access to hinges.

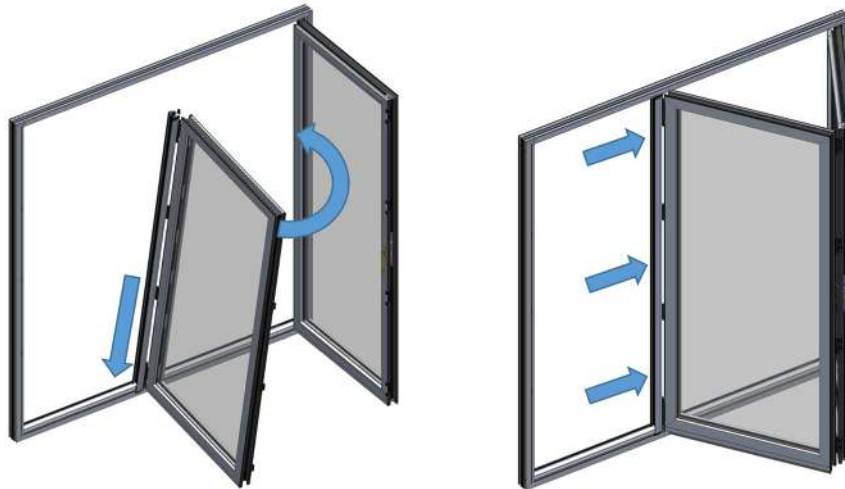

- Locate the hinge leaf over the fixing plate and secure with M5x10mm machine screws at top and bottom holes.

TOOL REQUIREMENT: - 3mm Allen key is required.

NOTE: - Do not use 4.2x25mm self drilling screws at this point.

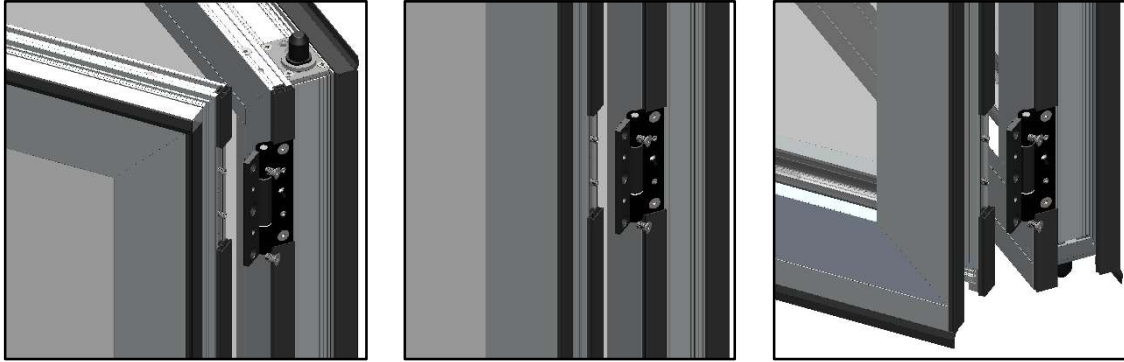

GLAZING INSTRUCTIONS

NOTE: - All glazing should conform in the requirements of BS 6262. In addition any instructions given by glass manufacturers should be followed.

- Before glazing, lock all doors panels and fully engage the locks.
- Starting from the first panel hinged to the jamb remove all beads, taking care to note where the beads are removed.

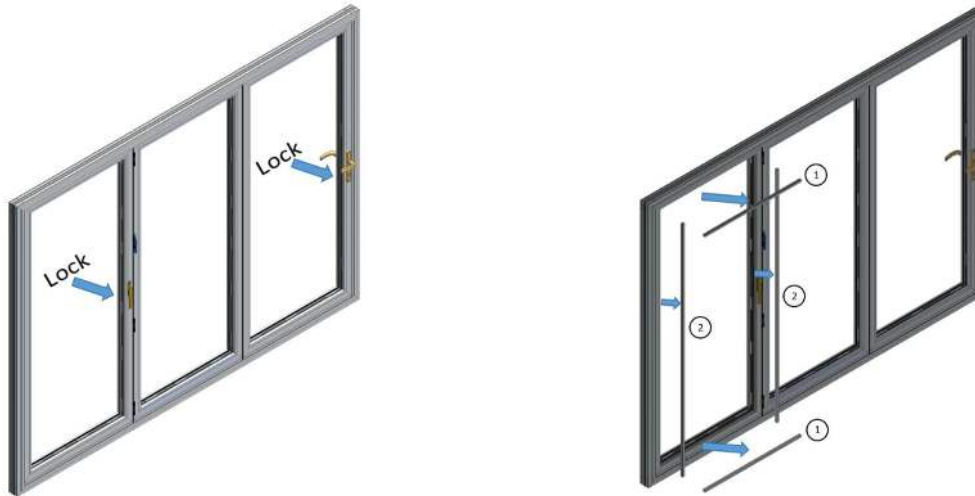

- Install the glass into the frame and pack it appropriately using various thickness glass setting blocks. Ensure to support inner and outer layers of the glass.
- All panels should be 'toe and heeled' to maintain equal and parallel gaps between outer frame and panel at the top and bottom.
- Add silicone between each vertical set of packers to help keep them in place. Make sure that all packers do not obstruct any of the drainage or decompression holes.

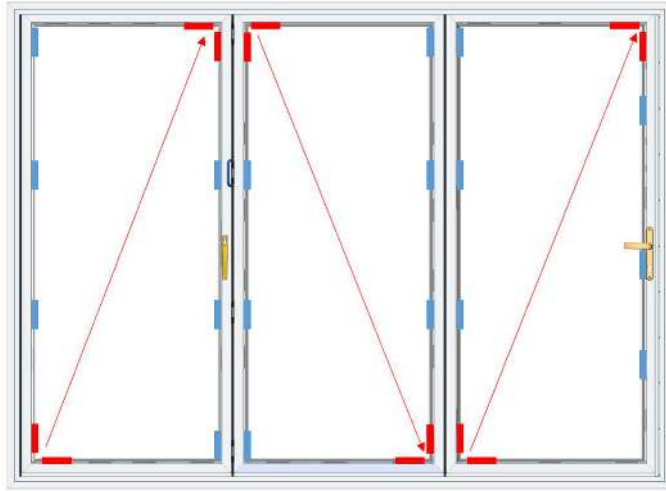

■ - 'Toe and Heel'. Load caring packer must be used to keep panels square and level.

■ - Supporting packers to prevent movement and provide rigidity to panel. Should be installed between all hardware components

- Replace beading, starting with shortest pieces first and tapping into place with a plastic mallet.
- Replace wedge gaskets into position.
- Repeat the 'toe and heeling' process for all panels, ensuring that all door gaps are equal and parallel.
- Check for door running operation and adjust if necessary.

OPERATION CHECKING AND ADJUSTMENT

Door unit operation inspection

- Check the basic running operation of the doors to make sure the mechanisms are working properly.

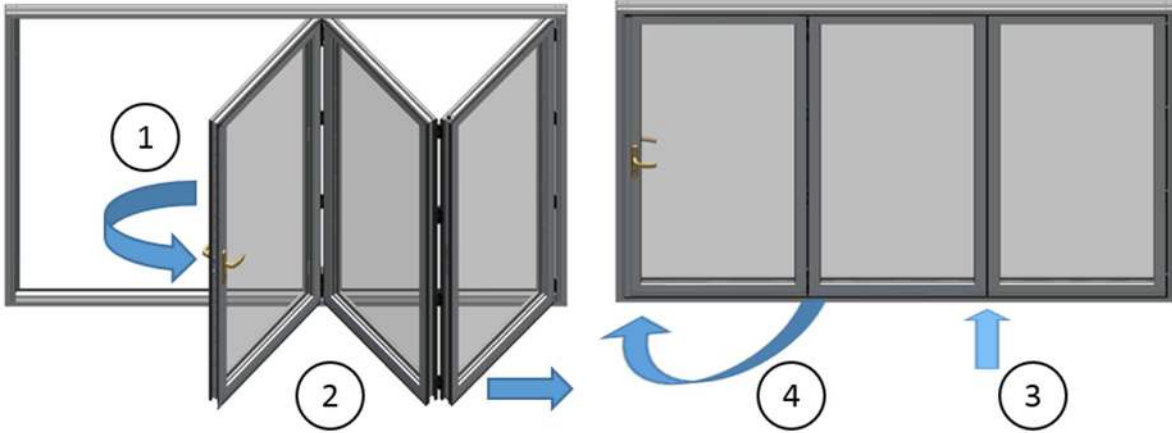

Overall gap size inspection

- Assess the horizontal gaps between the outer frame and sash at the top and bottom ensuring they are even and equal to 11mm.
- Assess the vertical gaps between the panel frames ensuring they are even and equal to 10mm.

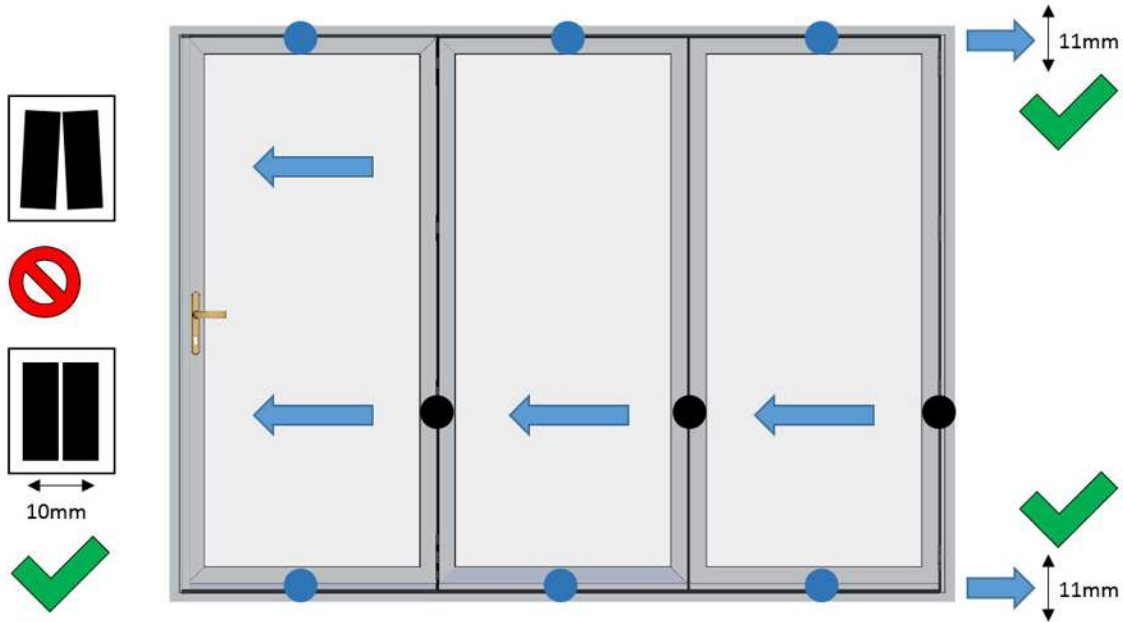

Master door adjustment

- Remove the rebate profile attached to the master door to see the gap where the lock and the keep are.
- Check the distance between the locking door and the outer frame. The distance should be 13mm.

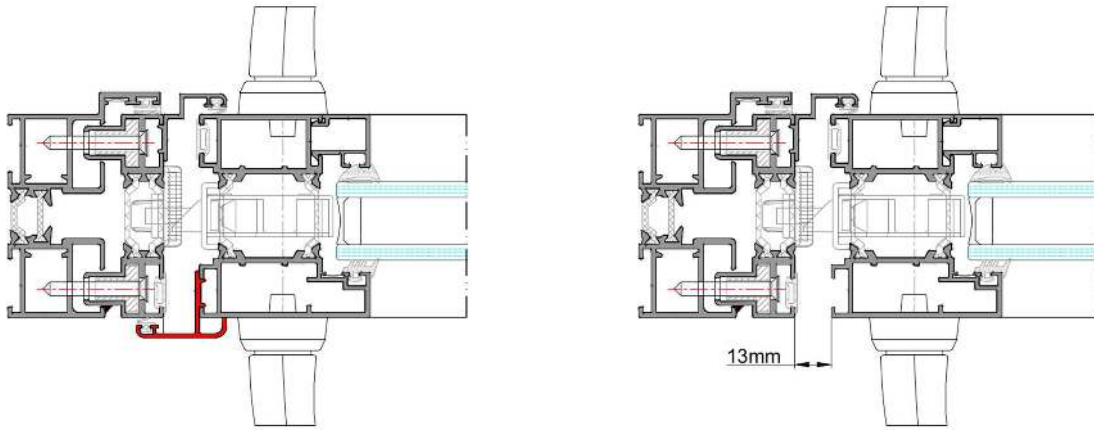

- If the lock and keep are clashing regulate the distance by adjusting adjustable jambs as shown below.
- Once the correct gap is achieved and the lock is locking perfectly fix the rebate profile back on the master door panel.
- Double check if the lock is latching properly.

Width adjustment using adjustable jambs

- To adjust the width release all bottom self-tapping screws that secures the adjustable jamb.
- Use grub screws to change the position of the adjustable jamb.
- Check the gaps to be equal and adjustable jamb is set square and level.
- After completing adjustment fix the adjustable jamb in position by securing self-tapping screws.



- Adjustable jamb is designed to have both positive and negative adjustment as shown below.

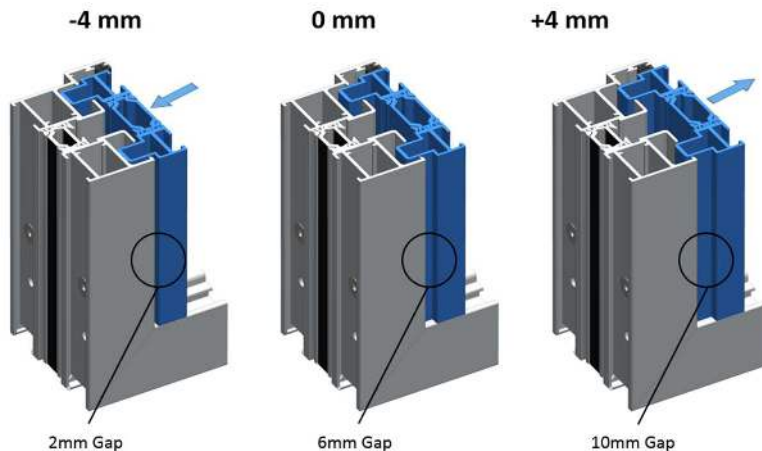

Securing hinges with final fixing screws

- After completing all the installation and the doors are glazed and operate properly, ensure to secure all hinges with final fixing screws as shown below.

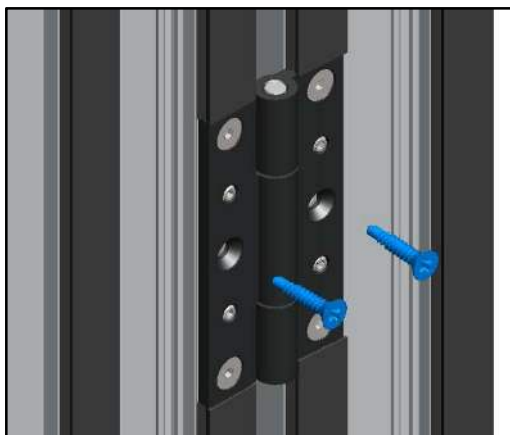
**Weather seal application**

- Apply missing or any removed weather seals on all panels and jambs. Ensure that the ribbed part of the seal would always be installed facing inner part of the profile.

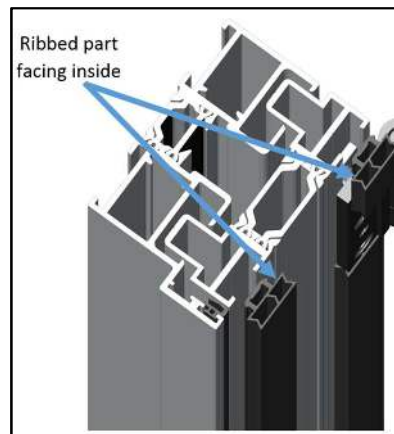
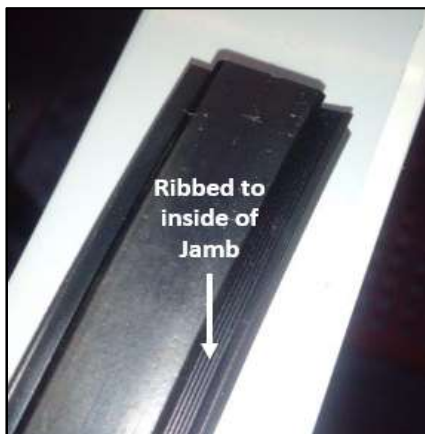

Panel catch installation

- Position the swing door at the point where it will stop.
- Ensure some clearance between the lever handle and next door.
- Use fully assembled panel catch pair to locate the position between two doors.
- Mark with pencil the position for panel catch on swinging door first.

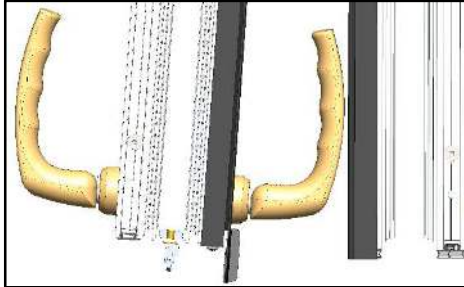

1. Position the door

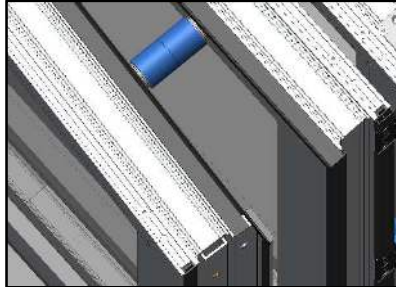

2. Locate panel catch

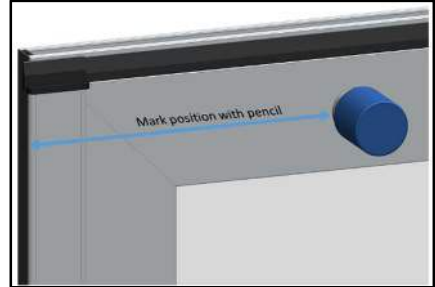

3. Mark position on swing door

- Unscrew panel catch back plate and fix it with choice of fixings provided in the box.
- Ensure the position for anti-rotation screw is pointed towards the hinge side.
- Secure the 3mm pointed anti rotation grub screw.
- Screw the outer sleeve.



4. Fix the plate



5. Position anti-rotation point

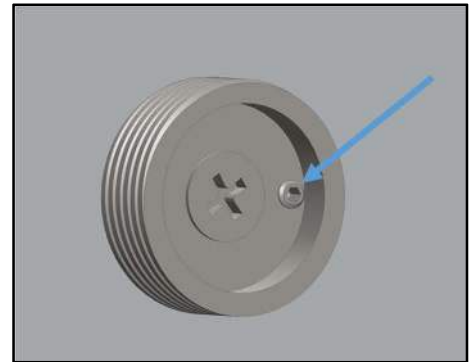

6. Fix anti-rotation screw

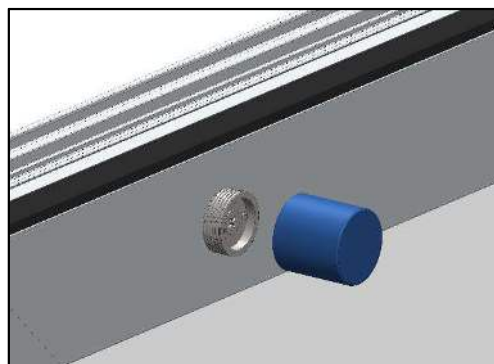

7. Screw the outer sleeve

- Mark the perfect position for panel catch on the opposite panel.
- Ensure anti rotation screw is pointed to the nearest swinging door hinge.
- Fix the second panel catch by repeating steps 4 - 7

FINISHING TOUCHES

- Check that the handles and locking mechanisms operate smoothly on each door.
- Check the bi-fold action is smooth and free running.
- Check that the locks operate correctly when closed.
- Check the door magnets are fully engaged when the doors are open.
- Check the hinges and ensure that there are no screws missing.
- Check the weather seal and ensure that the doors are fully sealed.
- Check the perimeter and ensure that the door unit is weather tight.
- Clean the bottom track and ensure it is free of any debris.
- Ensure that the homeowner is instructed and knows exactly how to use and look after bi-fold doors.

OPERATION AND MAINTENANCE

Opening and closing operation for bi-folding door with swinging door

To open doors

- Open the swinging door and connect it to the panel catch located on the next door.
- Release the shoot bolt locks on all other panels.
- Slide the folding panels starting from the pair nearest to the swinging door.

To close doors

- Slide each pair of folding panels back to align with frame
- Secure the panels by locking with shoot bolt lock.
- Close the swinging door last, ensure that all other panels have been locked in frame first.

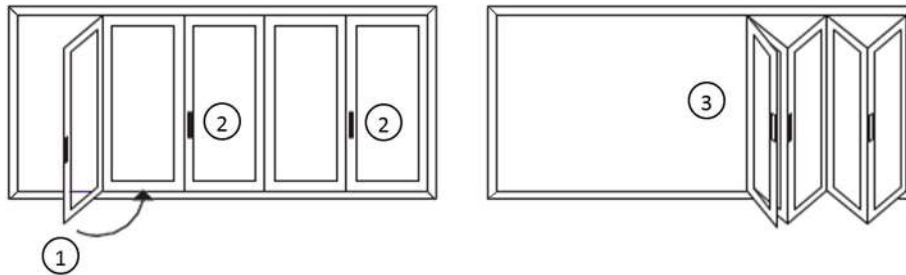

Opening and closing operation for bi-folding door without swinging door

To open doors

- Release the shoot bolt locks on all other panels.
- Slide each pair of folding panels away to one side.

To close doors

- Slide each pair of folding panels back to align with frame
- Secure the panels by locking with shoot bolt lock.

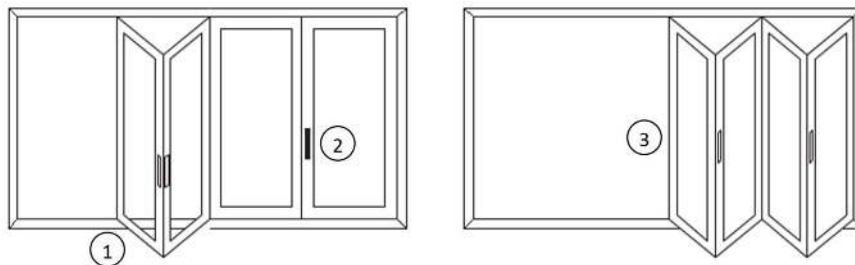

Maintenance

- Ensure top and bottom tracks are kept clean and free of any debris or foreign objects that can stop the function of the folding door.
- Ensure all door locking mechanisms are kept clean and any moving parts are regularly lubricated with light machine oil at least once a year.